

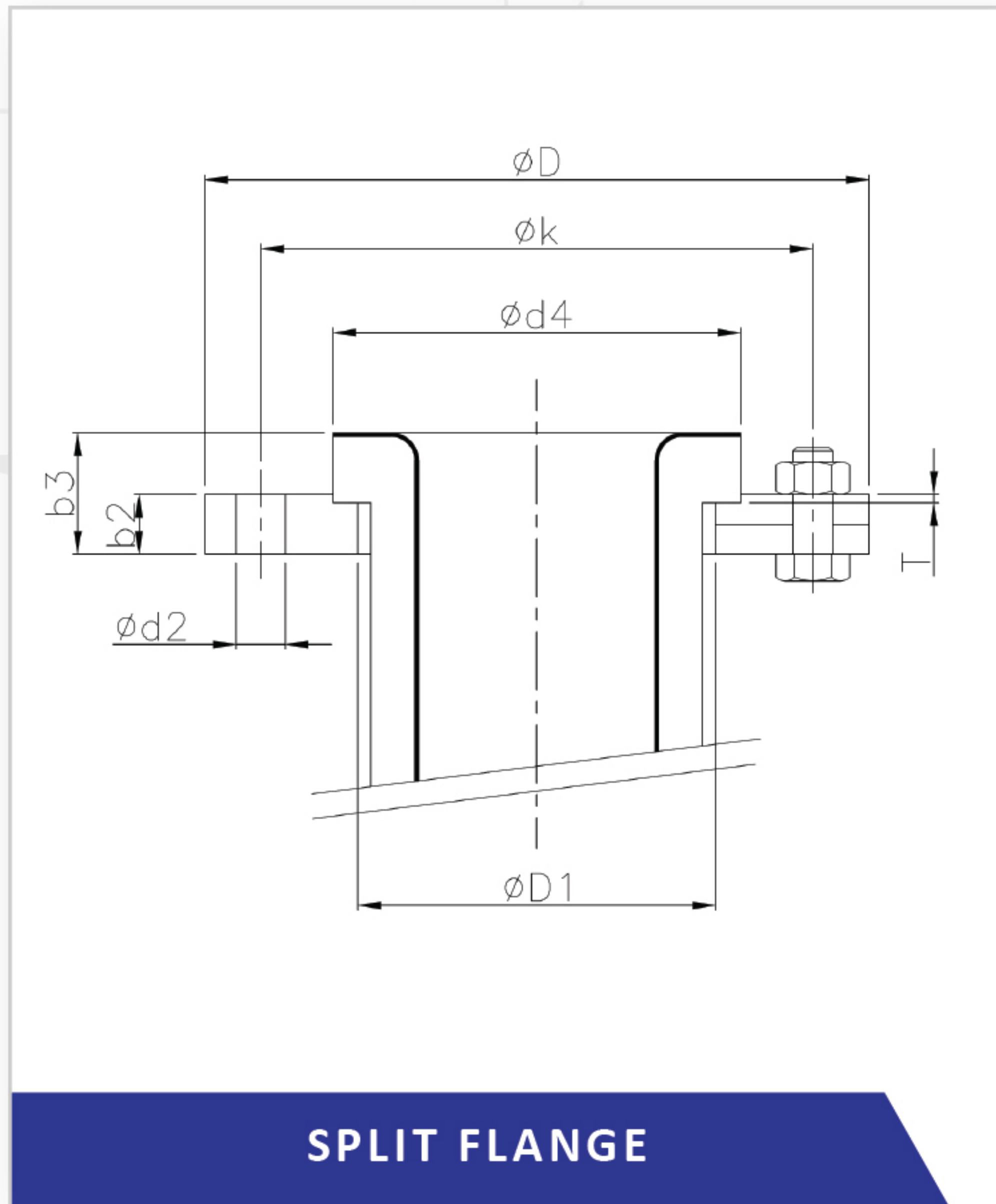

# SPLIT FLANGE



\*INCH TABLE

DN	PN	D	D1	d4	k	d2	b2	b3	T	daN	Weight 2xLoose flange+bolt
1"	150	108	46	63	79	4xØ15	14	25	2	0.7	2
1 1/4"	150	117.3	60	72	88.9	4xØ15.9	17.5	28.5	2	0.8	2.5
1 1/2"	150	127	63	83	98.5	4xØ15	14	25	2	0.9	2.7
2"	150	153	79	104	120.5	4xØ18	16	29	2	1.5	3.9
2 1/2"	150	177.8	90	107.9	139.7	4xØ19	24	37	2	3.2	4.1
3"	150	190	112	137	152.5	4xØ18	18	39	2	2.4	5.5
4"	150	229	136	160	190.5	8xØ18	20	35	2	3.8	9.6
4 3/8"	150	228.6	146	168.2	190.5	8xØ19	26.2	35	2	4.5	11
5"	150	254	165	193.3	215.9	8xØ18	33.3	47.5	4.8	7.6	17
6"	150	280	189	218	241	8xØ22	25	41	3	5.3	14.1
8"	150	343	238	273	298	12xØ25	28	46	3	8.5	20.7
10"	150	406	294	327	362	12xØ25	32	52	3	13.1	32.4
12"	150	383	357	384	432	16xØ25	35	58	3	21	48.2
14"	150	533.4			476.2	16xØ28.6	50	77		9.1	68.6
16"	150	596.9	447.7	474	539.7	20xØ28.6	50	72	5	43.2	103

